

Napoleonbob 500 Owner's Manual

Index

Foreword	2
Important precaution	3
I User notice	4
II Introduction to motorcycles	5
III Safe driving motorcycles	6
IV Operation instruction	8
4.1 Parts position	8
4.2 Instrument	9
4.3 Ignition switch lock	10
4.4 Right switch combination	11
4.6 Headlight Pitch angle adjustment	12
4.7 Opening method of fuel tank cap	13
4.8 Tire	13
V Operation guide	14
5.1 New vehicle running in	14
5.2 Inspection before driving	15
5.3 Start of motorcycle	16
5.4 Driving motorcycles	18
5.4.1 Shift operation	18
5.4.2 Climbing or turning driving	19
5.4.3 Use brakes	19
5.4.4 Park	20

FOREWARD

Dear users:

Sincerely thank you for choosing the BD500-30 two wheeled riding motorcycle designed and produced by our company! This car is independently developed and produced by our company, combining advanced technology and avant-garde design concepts at home and abroad. We hope that it can bring you a safe driving process and comfortable driving experience!

Before driving a motorcycle, please fully read the various regulations and requirements proposed in this practical manual!

This manual provides an overview of the repair and maintenance of this motorcycle. Please follow the various procedures in this manual for operation!

Our company has dedicated technical maintenance personnel and departments to provide you with excellent technical maintenance service support!

The company has always adhered to the service tenet of "making consumers more satisfied" and continuously improves product quality and performance. Any changes in appearance, color, and structure that may arise from this may result in inconsistency with this manual. We apologize for any inconvenience caused. The pictures in this manual are for reference only, please refer to the actual product for details.

Thank you again for your attention and trust in our company!

BENDA MOTORCYCLE

Important precaution

Please operate and drive according to this user manual, strictly abide by national and local traffic laws and regulations, and always pay attention to safety!

This user manual is one of the essential accessories of this vehicle. When the vehicle is resold to others, please attach it with the vehicle.

The copyright of this user manual belongs to Hangzhou Saturn Technology Co.,Ltd,Reproduction is not allowed without the written consent of our company, and violators will be held accountable.

The preparation of this user manual complies with the provisions of GB/T9969-2008 and GB/T19678-2005 standards.

Danger/Warning/Caution

Please read the content of this manual and remember the key points inside.

 **Warning:**

The items indicated by this word indicate precautions for operation to avoid damage to the motorcycle.

 **Warning:**

The items indicated by this word indicate precautions for operation to avoid damage to the motorcycle.

 **Attention:**

The item indicated by this word is a specialized explanation designed to facilitate maintenance or make important instructions more clear.

I、 User notice

1.1 Safety instructions for motorcycle drivers

For your personal and vehicle safety, please comply with the following six regulations:

①、 Properly wear various protective equipment

The protective equipment for cycling includes safety helmets, goggles, knee protectors, elbow protectors, and gloves.

Wearing protective equipment can greatly reduce the harm to the body when accidentally falling a car, and can maximize the protection of your personal safety.

②、 Familiar with vehicle construction

The driver's driving skills and understanding of the vehicle are the foundation of safe driving. Before officially riding a bicycle on the road, it is necessary to practice in an open area without other vehicles and be fully familiar with the vehicle and its handling methods.

③、 Understand the limit of one's safe speed

The driving speed depends on the ground conditions, your own skills, and the weather. Drive at a safe speed and within your skill range at all times. Understanding this limit will prevent accidents from occurring.

④、 Wear appropriate clothing

Loose and bizarre clothing can make driving uncomfortable and unsafe. Wearing suitable clothing on the saddle will allow you to move your hands, feet, and body freely. Therefore, try to choose high-quality tight fitting clothing.

⑤、 Inspection before driving

Please carefully read the instructions in the "Pre driving Inspection" section of this manual, and driving according to the rules can ensure the safety of you and passengers.

⑥、 Double attention to safety when driving on cloudy and rainy days

Pay special attention in rainy days. Remember that the Braking distance is twice as long as in sunny days. When driving, keep away from the hole cover, marking paint and greasy road surface to avoid skidding.

1.2 Number position (FIG 1)

①、 Vehicle frame number (VIN): Front end of the right frame (right side of the front pipe);

②、 Nameplate: Front end of left frame (left side of front pipe);

③、 Engine number: directly above the left side of the engine box;

Location map of nameplate, chassis number, VIN code, and engine number

Please fill in the frame and engine code below for future reference:

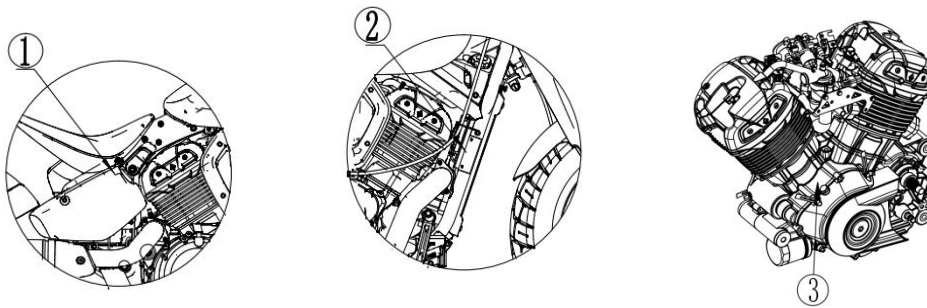

VIN	
Engine No	

II、 Introduction to motorcycles

The motorcycle has a compact structure, unique style, novel appearance, good driving stability, and comfortable riding. Adopting an electronic fuel injection system, it is more environmentally friendly and efficient, meeting national emission requirements.

2.1 Range of application of BENDA two wheeled motorcycles

BD500-30 is a self-developed two wheeled motorcycle, which is suitable for both urban roads and rural roads.

2.2 Characteristics of BENDA Two wheeled Motorcycle

- 1、 Strong power and heavy load
- 2、 High torque, strong climbing ability
- 3、 Electronic fuel injection system
- 4、 Advanced, professional water cooled engines in China
- 5、 Full DC power supply system

2.3 Carrying regulations

Number of passengers: 1 (including driver)

Maximum allowed load capacity: 75kg。

2.4 Fuel

Fuel grade: 92 octane or above unleaded gasoline.

Due to the flammable gasoline, If the fuel tank、 fuel filter、 fuel pipe、 throttle valve body and components leak due to damage or aging, they must be repaired in a timely manner before use.

Unleaded gasoline can extend the service life of spark plug and mufflers.

2.5 Electrical equipment

You are not allowed to install and change wiring of this vehicle on your own, nor can you modify electrical equipment on your own. Otherwise, it will overload the electrical system, causing the circuit to overheat, causing fuses to melt or the circuit to short-circuit, and even generating sparks, causing danger such as burning the car.

⚠ Danger:

Our company shall not be responsible for any consequences caused by the installation or modification of our vehicle's wiring or electrical equipment.

2.6 Inspection

You should strictly follow the requirements in the "Maintenance Schedule" to maintain your vehicle.

III、 Safe driving motorcycles

This motorcycle is a two wheeled motor vehicle can bring convenience and speed to rider,To ensure your motorcycle' best performance,you should compliment the correct maintenance and upkeep .When using the motorcycle,it must be safe and normal;when driving or riding it,your body must be healthy so that you can drive the vehicle at your best condition.

⚠ Danger:

Driving a motorcycle must comply with traffic regulations; Before driving, the vehicle must be carefully inspected.

3.1 Safe driving rules

- 1、 It is necessary to inspect the motorcycle is safe and normal carefully before starting the motorcycle.This can avoid accidents and damage the components.
- 2、 Motorcycle drivers must pass the traffic management and obtain the motorcycle driving license.Do not lend motorcycles to people without a "motorcycle driver's license" for use.
- 3、 To avoid harm you should:
 - Wear eye-catching clothing
 - Do not drive too close to other vehicle and use signals as turn signals, horns and brake lights.
 - Please do not drive in the blind spot of other drivers.
- 4、 Comply with traffic rules strictly
 - Speeding is the main factor leading to motorcycle accidents.If encountering rainy and snowy weather and gravel roads, intersections and other road conditions.It is necessary to drive at low speed and slow down carefully.
 - When turning and changing lanes , signal device such as turning signals must be turned on to attract drivers' attention.
5. Drivers should hold the steering handle tightly with both hands and step on the front pedals with both feet; Passengers should tightly grasp the armrest or hold the driver's waist with both hands, and step on the rear pedals with both feet.

3.2 Safety protection equipment

- 1、 Most the injuries of motorcycle accidents are head injuries.Therefore drivers and passengers must wear helmets that meet safety and quality standard as well as dust proof glasses and gloves.
- 2、 When driving,exhaust muffler's temperature is so high, to avoid contact burns, both drivers and passengers should wear long boot and other equipment.
- 3、 Do not wear loosen clothing to prevent accidents from catching the steering handle , clutch handle, pedals or nearby vehicle.

3.3 Refitting

⚠ Warning:

1. Arbitrary modification of the motorcycle or replacement of the original device cannot guarantee the safety of the motorcycle and is illegal. You must comply with the regulations of the traffic management department on the use of the vehicle.
- 2.To ensure that the exhaust emission can meet the national emission requirements, you cannot modify or remove the following parts without authorization.
 - (1) You cannot adjust the idling speed at will;
 - (2) As the exhaust muffler is equipped with optimized catalyst, if the exhaust muffler is damaged, please go to the designated maintenance unit for repair or replacement.
- 3.If there is a good modification suggestion, you can write to our company, and our company will be specifically responsible for the implementation after confirmation. The company will not be responsible for any unauthorized

⚠ Danger:

We will not be responsible for any dangerous consequences such as short-circuiting of wires, blowing of fuses, burning of the car due to exceeding the rated power of electrical appliances or generating of sparks if you modify the cables and electrical appliances by yourself.

⚠ Attention:

Improper or overweight loading of motorcycle cargo will affect the performance of the vehicle, reduce its driving stability, and easily cause safety accidents.

The modification or removal of original parts from motorcycles may result in reduced safety or illegal driving of the vehicle. Please follow all regulations in your region.

When loading goods:

- 1、 The goods should be loaded at the center and lower, close to the center of the vehicle.
- 2、 Adjust the pressure of tire according to load weight and drive conditions.
- 3、 All goods should be fixed on the vehicle firmly to ensure the stability of control.
3. Do not attach large or heavy objects to the steering handle, front shock absorber, or front mudguard, as this may cause unstable driving or poor steering.
- 5、 It is strictly prohibited to exceed the maximum loading weight of 75kg.

3.4 Accessories

All accessories pass the test. Therefore our company is not responsible for any adverse consequences caused by installation of non original accessories.

You should inspect them carefully if install the non original accessories: visual impairment, ground clearance, lateral tilt angle, steering flexibility of control mechanism, ease of operation, performance of accessories.

IV、 Operation instruction

4.1 Parts position



图 1

1、 (Fig1)

- ① Front headlight
- ② Front left turn signal
- ③ Front left mirror
- ④ Battery (Battery box inside the protective panel)
- ⑤ Seat cushion
- ⑥ Rear left turn signal
- ⑦ Rear license plate light
- ⑧ Front Brake Caliper
- ⑨ Shift lever
- ⑩ Front left foot pedal
- ⑪ SIDE STAND

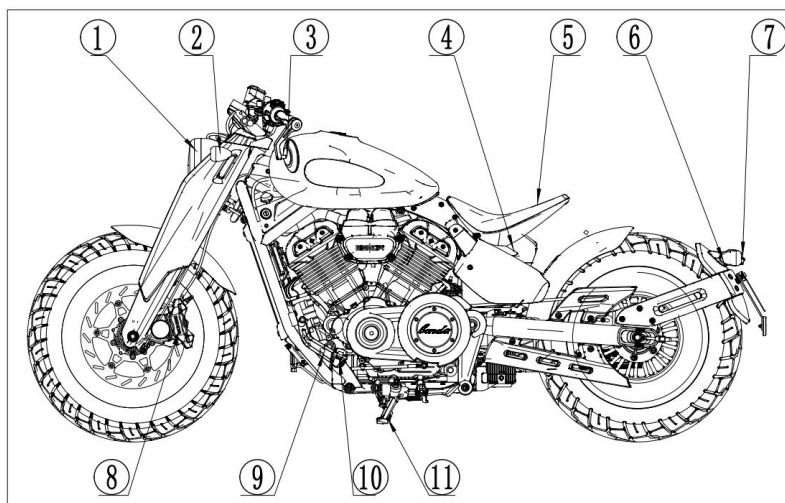
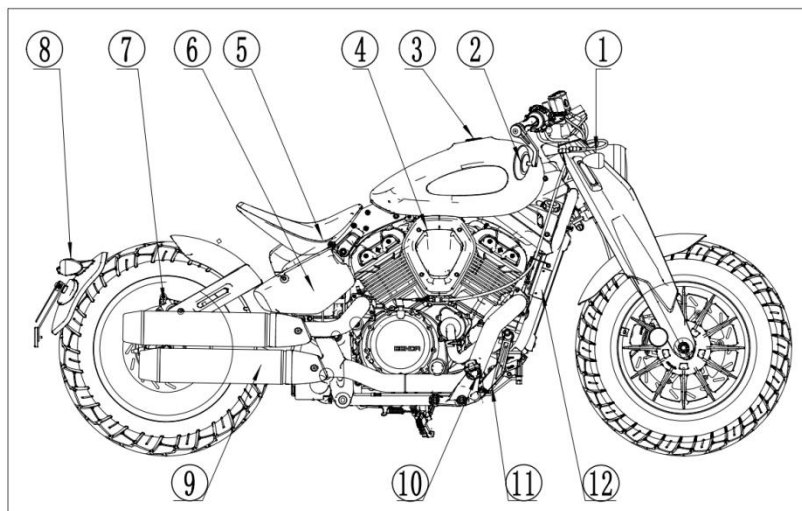

2、 (Fig2)

- ① Front right turn signal
- ② Right rear mirror
- ③ Fuel tank cover
- ④ Air filter
- ⑤ Frame VIN code
- ⑥ Rear shock absorber (under the protective plate)
- ⑦ Rear brake caliper
- ⑧ Rear right turn signal
- ⑨ Exhaust muffler
- ⑩ Right foot pedal
- ⑪ Brake pedal
- ⑫ Nameplate

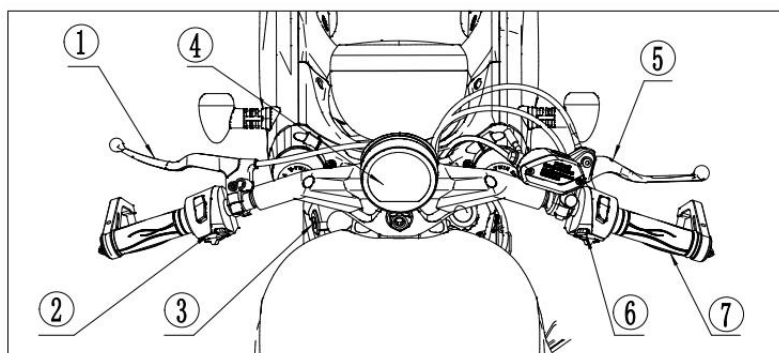

3、 Front car body (Fig3)

- ① Clutch handle
- ② Left switch combination
- ③ Ignition lock
- ④ Instrument
- ⑤ Front brake handle
- ⑥ Right switch combination
- ⑦ Throttle lever sleeve

4.2 Instrument

Instrument (=FIG4)

Please refer to Table 1 for the names and functions of indicator light symbols

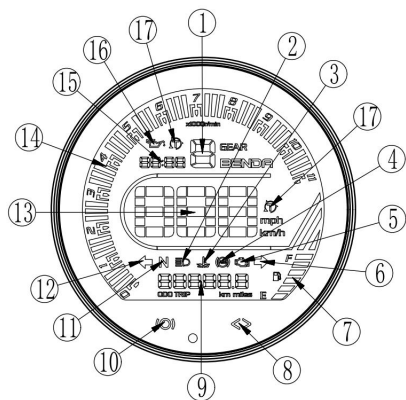

Fig4

No	Name	Function
1	Gear display	Display the location of the engine
2	High beam indicator	The high beam light is on, and when it is lit, it displays blue
3	Water temperature alarm indication	Illuminate and display in red: coolant overheating, cooling system malfunction
4	ABS indicator	Display ABS status
5	Electronic fuel injection malfunction indicator light	After the engine is running, the light will turn off. If there is a fault, it will display a yellow light flashing
6	Right turn indicator	The front and rear right turn signals flash, and when illuminated, they display green
7	Fuel quantity indicator	Display the remaining fuel in the fuel tank
8	Right touch button	Details can be found below
9	Mileage display	The total mileage traveled by the vehicle
10	Left touch button	Details can be found below
11	Neutral indicate	Illuminates green when in neutral
12	Left turn indicate	Illuminates green when front and rear turn signal flashing
13	Speed indication	Instantaneous speed
14	Rotational speed indication	Illuminate instantaneous speed of engine
15	Time/oil pressure fault indication	Display current time/oil pressure fault (E-01)
16	Oil pressure indicator	The light comes on when there is a malfunction in the oil pressure
17	TCS indication	Display TCS status

Tips: “Left touch key” Switch between total and subtotals of driving mileage during a single press. When in subtotal mode, press and hold the left touch button to reset the subtotal mileage to zero.

Long press the right touch button enter into clock setting mode, at this time, press the “right touch button” once to switch the required adjustment position of the clock. Single press “left touch button” can adjust the time.

4.3 Ignition switch lock, steering switch, seat lock

Ignition switch (Fig5) set in the front left of the vehicle, it must be turned on before starting the motorcycle.Key positions and functions are shown in Fig2.

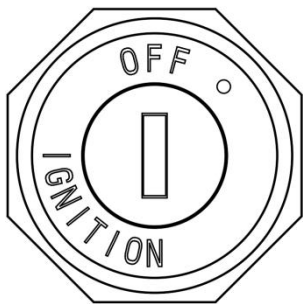
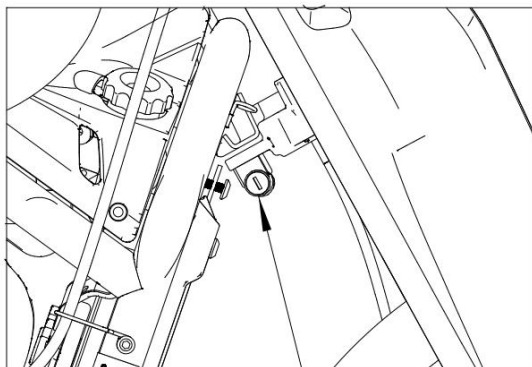

Fig5

Key position	Function	Key status
Close "OFF"	Circuit disconnected ,engine unable to start	Can be pulled out
Open "O"	The circuit is closed and the engine can start	Can not be pulled out
<p>⚠ Attention: 1. When not use the vehicle,turn the key to "OFF"position and remove the key</p>		

Table2

Steering lock (Fig 6) Installed at the lower link board. Lock the steering mechanism when parking and not in use.



Steering lock

Fig6

⚠ Attention:

Before locking the steering mechanism , The vehicle needs to be parked properly.After locking ,the motorcycle can not be pushed ,making it difficult to balance and prone to rollover

4.4 Right switch combination (Fig 7)

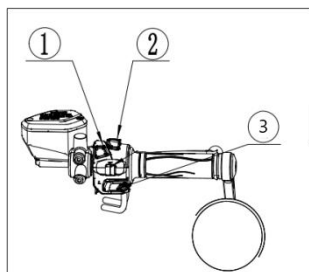





Fig7 Right switch combination

- ① Hazard warning flasher
- ② Turn off preset switch
- ③ Electric start button

1、Flame-out preset switch

Flame-out switch located on the right of the steering lever, preset switch has two position: “” and “”

Turn off “  ”	Turn off the ignition switch-At this position, the ignition circuit is disconnected, The running engine is turned off and cannot be started.
Turn on “  ”	Turn on the ignition switch - it needs to be switched to this position during operation, and the ignition circuit has been closed.

2、Electronic start button

Ways: After doing the start preparation (Page 7), press on the electronic start button “”, If necessary simultaneously rotate the throttle lever to add fuel appropriate then you can start the engine.

(Fig9)

4.5 Left switch combination (Fig8)

- ① Overtaking light switch
- ② ABS function switch
- ③ High and low beam switch
- ④ TCS function switch
- ⑤ Horn switch
- ⑥ Turn signal switch

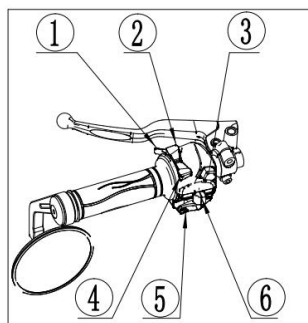

Fig8 Left switch combination

1、Overtaking light switch

When the "overtaking light button" is pressed, the overtaking light will light up;





When the "overtaking light button" is released, the overtaking light does not light up.

⚠ Attention:

The current headlight is in high beam mode “”, Overtaking lights do not work.

2、Head light dimmer switch

Head light dimmer switch has two running state: Turn on the ignition switch lock, And “Head light、 position light switch” move to “” this position.

Low beam “  ”	“Head light dimmer switch” move to “  ” is low beam status
High beam “  ”	“Head light dimmer switch” move to “  ” is high beam status

⚠WARNING:

Please adjust the high or low beam according to road condition. If there are oncoming vehicles, please turn the light to the low beam light state to avoid dazzling light affecting the driving state of oncoming drivers and causing traffic accidents.

3、 Turn signal switch

When turn left, move “turn signal” to “”; Front and rear turn signal light of left, the left turn indicator light is on of the instrument.

When turn right, move “turn signal switch” to “” position; Front and rear turn signal light of right, the right turn indicator light is on of the instrument.

Move the turn light switch to middle position: Then left, right turn light and indicator light are not light up.

⚠Warning:

When turn or change the lane we must turn on the turn signal switch, And turn off the turn signal till finish turning or changing the lane.

4.6 Headlight Pitch angle adjustment (Fig9)

Due to user’s height and observation habits, So have different requirements to light for night time drive. To give the user a better drive experience in night, The front headlight was designed specially with a adjustable angle. User can adjust according to self need. Ways as followings:

The first step、 Use 6# Hex key、 10# open spanner loosen the upper and lower fixing screws that secure the front headlights

The second step、 After loosening the screws .Rotate the light with lower fixing screws as the axis ,then adjust to proper position and fasten the screw.

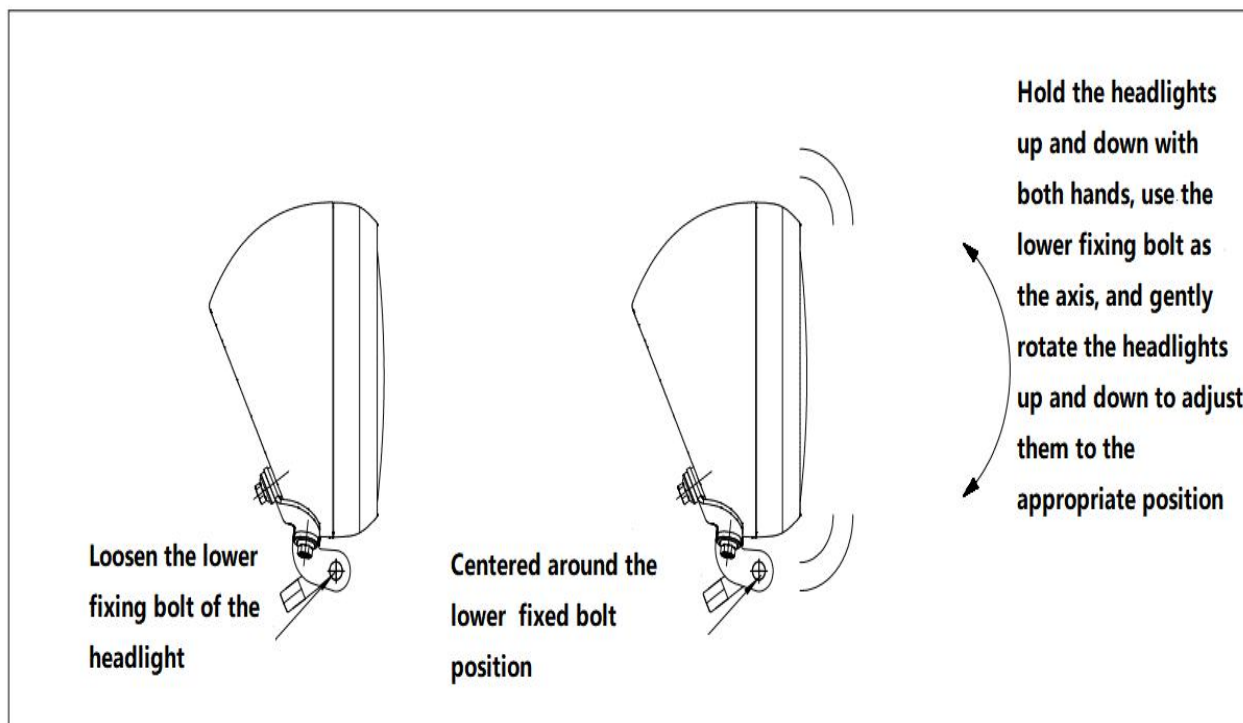

Fig9

⚠ Attention:
Headlamps have no pitch angle limiting structure. Please adjust according to actual needs.

4.7 Opening method of fuel tank cap (Fig10)

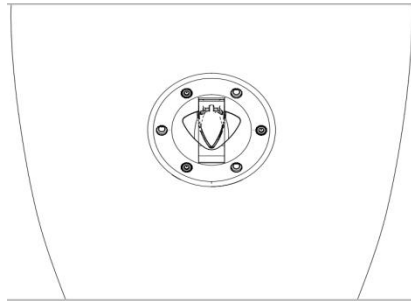

Fig10 Fuel tank cover

Open the small cover that covers the keyhole, insert the key into the fuel tank lock hole, and rotate clockwise to open the fuel tank lock; When closing, remove the key, gently close the fuel tank cap, and press firmly until you hear a "click" sound. Finally, cover the small lid that covers the keyhole.

4.8 Tire

Correct tire pressure will ensure: stable driving、comfortable driving、endurable tire.Tire pressure should inspect at cold tires.

Tire specification and pressure referenced to Fig 3 :

Cold tire pressure	Single			Double		
	kPa	kgf/cm2	psi	kPa	kgf/cm2	psi
Front wheel	225	2.25	33	225	2.25	33
Rear wheel	225	2.25	33	225	2.25	33

Table3

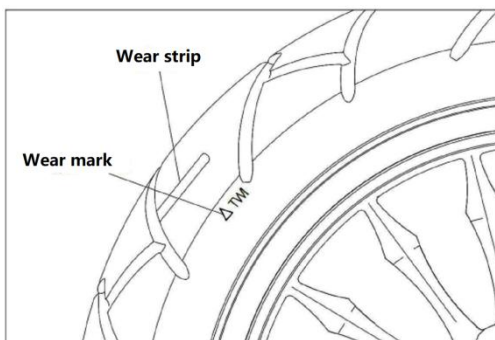

Fig11 Inspection of the tire

Determine tire state.Incorrect tire specification will influence manipulate performance.Damage and wear on the tire will lead to the tire lose control.Over wear of the tire will lead to perforation and lose control.Tire's wear also influence appearance and manipulate performance.

Inspect the state and pressure of the tire before using.If many obvious wear like wear,scratch or worn to their limit position,must change the tire.

⚠Attention:

- 1、 When pressure of tire decline , Inspect if have nail,small hole on the tire.Is the side of the wheel rim damaged.
Tires without inner tubes will gradually deflate when they have small holes.
- 2、 Incorrect pressure of tire will lead to abnormal wear of tire tread ,Even causing safety accidents.
- 3、 Insufficient tire pressure may cause tire damage or detachment from the wheel hub.

⚠Warning:

- 1、 The triangular mark indicates the position of the wear strip.If wear strip touch the ground,that means tire has reach to the limit and should change the tire.
- 2、 When change the tire , determine the size and type of tire should accord with table 3.If change the tire of different size or type,it will affect the performance of manipulating the motorcycle and cause it lose control.
- 3、 After repairing or changing the tire , we should balance the wheel which is very important.Because it can avoid the touch between tire and ground , also avoid some uneven wear.

⚠Danger:

- 1、 Sealing of tubeless tires at the contact area between the rim and tire lip.To avoid air leak, Disassembling and installing tubeless tires requires special tools to protect the rim and tire lip, using a specialized tire disassembly and assembly machine.
- 2、 Repair the small hole of tubeless tire need dismantle the tire and apply the patch inside.Do not use external repair method. Because when turning,the centrifugal force of the tire can loosen the repaired area.The centrifugal force will cause the loosen of repair position 。 Within 24 hours of repairing the tires.Speed can not over 80km/h,later the speed can not over 130km/h.If over speed,The heat generation of tire increase sharply, will render the repair ineffective,cause tire air leakage.If side of tire damaged , or position of tire damaged over six millimeters , the tire can not be repaired to

V、 Operation guide

5.1 New vehicle running in

Run-in period is the initial period of use of the new vehicle,a method to ensure that the bonding surface between parts becomes the optimal bonding state.Correct run in operation can improve the life time of vehicle to the maximum extent possible.

New vehicle run in mileage: 1500km

1、 In the running in period : Throttle should be avoided full open,Engine's maximum speed can not exceed 6500 rpm(Instrument): Speed should be controlled within the following range

0~300km Run in :

Throttle handle should be opened to avoid exceeding 1/2 of the maximum opening; Vehicle speed within 50km/h.

300~600km Run in:

Throttle handle should be opened to avoid exceeding 2/3 of the maximum opening; Vehicle speed within 60km/h

600~1500km Run in:

Throttle handle should be opened to avoid exceeding 3/4 of the maximum opening; Vehicle speed within 70km/h.

2、 Avoid sustained low speed: Engine runs at a certain low speed (light load) ,Will cause smooth grinding of components and poor running in.

3、 Use every gear properly: Do not drive Continually at a fixed speed of engine,Can change the speed ,enable every components of engine to undertake pressure, Which can make the engine run in better.

4、 Before driving,first circulate the oil: After start the hot or cold engine,before operating without applying load to give the engine sufficient idle time,this can lubricate all important components of the engine with oil.Reduce the wear, prolong the life time and can also preheat the engine.

5、 New tire's run in: Tire also need to be run in,Before running in the new tire,Within 160 km you should increase the turning inclination angle,but avoid sudden braking rapid acceleration sharp turns.

6、 Run in period repair: Please repair when driving the new vehicle over 1000km,In the run in period, other parts have already engaged.This time all components should be adjusted properly Then change the oil.

⚠ Danger:

Poor tire running in will cause slip or lose control.When using new tire should be very careful,Run in the tires within the first 160 kilometers (100 miles)

⚠ Attention:

When the vehicle is in poor condition, it needs to be repaired before 1000 kilometers.

5.2 Inspection before driving

To ensure driving safe,please check this vehicle before using it; If there are any abnormal phenomena during the inspection, they must be repaired and resolved before use.

The following procedures can be followed for inspection:

1. Check the lubricating oil inside the engine (see page 16) and ensure that there are no leaks;
2. Check if the fuel is sufficient;
3. Check if the coolant in the cooling system is sufficient and ensure that there are no leaks;
4. Check the front and rear brakes: free travel (5-10mm in the front and 10-20mm in the back), smooth operation;
5. Check the front and rear tires: air pressure, depth of tread wear, cracks (see page 10);
6. Check the transmission belt: the tightness is suitable, there are no defects or damage;
7. Check the throttle handle: free clearance (2-6 mm), and whether refueling or refueling is easy to operate;
8. Check the lighting and signal lights: ensure that the headlights, tail lights, brake lights, turn signals, indicator lights, and horns are in good condition;
9. Check the battery electrolyte and add distilled water in a timely manner (see page 24);
10. Check the steering device: it should be stable, rotate flexibly, without looseness or axial movement;
11. Check the clutch handle: free clearance (5-10mm) and smooth operation;
12. Tightening bolts and nuts: front and rear shock absorbers, wishbones, front and rear wheel axles, engine suspension, steering system, steering lever, front and rear brakes, clutch, rear suspension system, electrical components, etc.

⚠ Warning:

No inspection before driving and proper maintenance will leave safety hazards behind.Inspecting motorcycles before riding can eliminate safety hazards.

5.3 Start of motorcycle

(Fig13)

- 1、 Turn on the ignition lock,move the flame-out preset switch to “” position.
- 2、 Shift the gear to low or neutral.

3、 Fully grip the clutch lever with the left hand (release the clutch when not in neutral).

4、 Press on the electronic start button“(多)”, If necessary, turn the throttle handle and add fuel appropriately to start the engine.

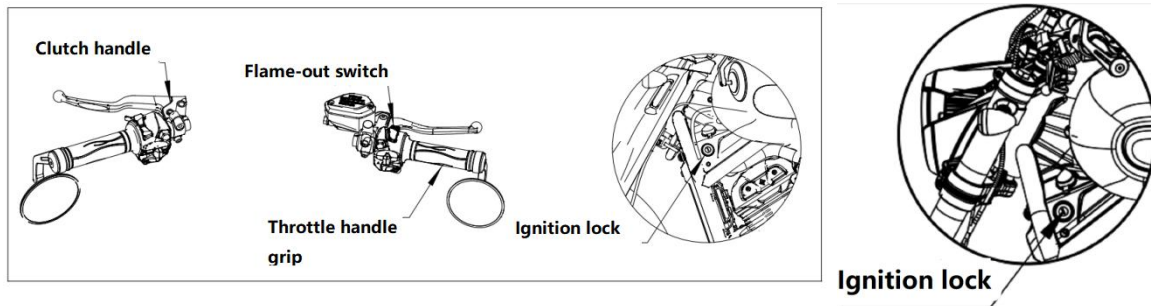

Fig13 Start preparation

⚠ Danger:

1. To avoid errors and danger caused by rushing forward during startup, shift to neutral and do not use the fuel door.
2. When not driving, the engine speed should not be too high and the idle time should not be too long, otherwise it may cause the engine to overheat and damage internal components, and cause discoloration of the exhaust pipe muffler.

⚠ Danger:

1. If you are driving this type of vehicle for the first time, we suggest that you practice on a non-public road until you become familiar with the control and handling methods of this vehicle.
2. One handed driving is the most dangerous, one should firmly grasp the steering wheel with both hands and place both feet on the pedals while driving. Regardless of the situation, do not drive with both hands off the handlebars.
3. Reduce the speed to a safe speed before turning.
4. The road surface is damp and smooth, and the tire friction is low, resulting in a natural decrease in braking and turning ability. Therefore, it is necessary to slow down in advance.
5. Cross winds are usually most likely to occur at tunnel exits, valleys, or when large vehicles overtake from behind. You must be careful and calm, slow down while driving.

⚠ Attention:

1. After starting, it should be preheated for 2-3 minutes before driving on the road. An engine with insufficient preheating temperature will exacerbate the wear of components such as cylinders, piston rings, and rocker arms during operation.
2. When using the electric start button, it should be immediately released within 3-5 seconds of each operation; Otherwise, it is easy to cause the battery to discharge too quickly and affect the service life of the battery.
3. After the engine starts, the electric start button should be immediately released; When the engine is running, it is not allowed to press the electric start button again, otherwise the engine may be damaged.
4. Ensure that the single brace is fully retracted to avoid driving obstruction and control failure when turning left.
5. After starting or during driving, it is necessary to refuel smoothly (by turning the throttle handle).
6. Do not start the motorcycle in a narrow space to avoid the risk of poisoning caused by the difficult diffusion of exhaust gases.
7. If the clutch switch fails, it should be replaced in a timely manner.
8. It is strictly prohibited to start the engine before the clutch is disengaged, otherwise it may cause component damage or safety accidents.

5.4 Driving motorcycles

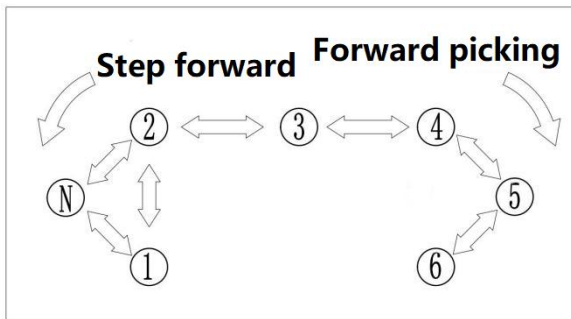

Fig14 Shift position

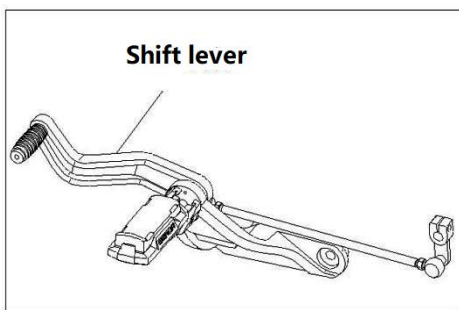

Fig15 Shift lever

5.4.1 Shift operation (Fig14, Fig15)

This vehicle has a six speed constant engagement; ①、②gear are low speed,③、④gear are medium speed,⑤、⑥gear are high speed.Gear shifting can refer to the following operations:

1) Shift from neutral to ① gear: Return the throttle with the right hand, quickly grip the clutch handle with the left hand, and press down on the gear lever with the left foot once,Enable the transmission into①gear,Gradually release the clutch handle with the left hand and gradually fill the fuel door with the right hand.Action coordinate and enable the motorcycle ride smoothly at ① gear.

2) ①gear to②gear : Right hand throttle return, Quickly grip the clutch handle with your left hand and hook the gear lever up with your left foot once , making the transmission into ② gear,Gradually release the clutch handle with the left hand , Right hand gradually refueling door 。 Good coordination of movements.Enable the motorcycle drive at a stable ② gear.

3) The method of shifting from② to ③④⑤⑥ is same to shift ①to②.

4) The method of downshifting is the same as shifting from neutral to ①.

Warning:

- 1、 Do not shift gears without returning the throttle or gripping the clutch lever,otherwise it may cause damage to the engine and transmission system and lead to safety accidents.
- 2、 When shifting gears, please confirm that the gear lever is pressed in place before releasing the clutch lever.
- 3、 When shifting or gripping clutch handle, clutch out.Motorcycles rely on inertia to travel, therefore,minimize the shifting time ASAP.
- 4、 When driving at high speed, suddenly lower the gear or quickly return the throttle,low engine speed and high rear wheel speed. When loosening clutch handle , Friction and engagement deceleration of the clutch pads cause rear wheel braking, Loss of control leading to accident.Therefore.When changing from high-speed to low-speed driving, it must slow down and then lower the gear.
- 5、 Do not use low-gears for high speed driving or high gears for low speed driving.Otherwise it will cause damage of the engine.
- 6、 Before accelerating the gear must be uplifted to allow the engine to operate within the normal speed range.No gear should cause the engine speed to be too high.

⚠ Attention:

- 1、 Before switching the low gear, lower vehicle speed or increase the speed of engine。 Before shifting into high gear, increase the vehicle speed or decrease the engine speed. This can prevent unnecessary wear of transmission system components and rear tires.
- 2、 When the gear is in neutral and the neutral indicator light is on, it is best to slowly release the clutch handle to confirm whether it has truly entered the neutral position

5. 4. 2 Climbing or turning driving (Fig15)

- 1) When driving uphill, there will be a deceleration phenomenon where the gear is too high and the power is insufficient. Therefore, it is necessary to quickly lower the gear before driving uphill.
- 2) When driving downhill, the gear must be lowered, intermittent use of front and rear brakes. If the front and rear brakes are used continuously for a long time, it can cause the brakes to overheat and reduce braking effectiveness, posing a danger.
- 3) When going downhill, do not turn off the ignition switch or the engine flame-out switch to coast, otherwise it will reduce the lifespan of the catalyst inside the exhaust muffler.
- 4) Before turning, you must first use the brakes to reduce the speed and then lower the gear. Otherwise, driving too fast and rushing out of the bend, or using the brakes during turns can cause dangerous accidents.

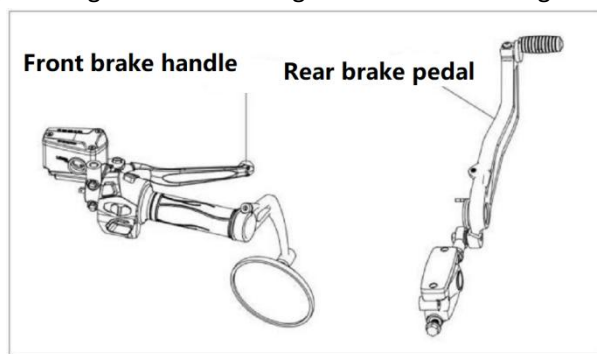

Fig15 Rear brake pedal

5. 4. 3 Use brakes

- 1) When decelerating, both front and rear brakes must be used simultaneously. (Slowly grip the front brake handle with your right hand and step on the rear brake pedal with your right foot to avoid using the front and rear brakes separately). Avoid decelerating too quickly, which may cause clutch slippage.
- 2) In emergency situations, simply turn off the ignition switch and use both the front and rear brakes to stop the vehicle.
- 3) Try to avoid sudden braking. Because sudden braking can cause the front and rear wheels to suddenly stop, making it difficult to control the vehicle.
- 4) Avoid sudden acceleration, sudden braking, and sharp turns on wet or soft road surfaces. Prevent vehicle skidding that is difficult to control.

5. 4. 4 Park

- 1) Gradually return the throttle until it fully returns.
- 2) At the same time, slowly grip the front brake lever with your right hand and step on the rear brake pedal with your right foot to avoid using the front and rear brakes separately.
- 3) When the speed decreases, lower the gear.
- 4) Grasp the clutch handle tightly, shift into neutral, and then come to a complete stop. After shifting into neutral, the

neutral indicator light on the instrument panel lights up.

5) If you want to park on a gentle slope with a single support, you should shift to a lower gear and keep the front of the car uphill to avoid overturning. (Be sure to shift to neutral position when starting again)

6) Turn off the ignition lock; In emergency situations, the engine can be turned off by directly turning off the ignition switch.

7) Lock the steering mechanism and remove the key to prevent theft.

 Danger:

1. The higher the vehicle speed, the longer the braking distance will be. Therefore, it is necessary to maintain a safe distance to prevent rear end collisions. (Frequent use of only the rear brake will accelerate the wear and tear of the braking system, and the braking distance will become longer.)

2 Using only the front or rear brakes can cause slipping and loss of control. Be cautious when using the braking